

RAHMANN GmbH

Quality for the future



Electro - linear cylinder type LT..



ELECTRO- LINEAR CYLINDERS

General:

To respond to the increasing demand of favourable actuation systems the RAHMANN - electro linear cylinders were developed.

Everywhere, where pneumatic- and hydraulic systems for economical and ecological reasons cannot be used, provide RAHMANN - electro linear cylinders a safe solution.

Applications for RAHMANN - electro linear cylinders are e.g. in the conveyor technique, fluidics and process engineering.

To the field of activity of the RAHMANN - electro linear cylinders involve among other things the positioning and direction of objects, the proportioning of bulk materials and the control of fluidities. Furthermore the movements of stroke, tilt-, push- and pull motions can be converted.

Assembly and description of function:

An IEC standard motor (1) activates an acme thread spindle (3) via a worm gear (2).

From the rotary motion of the motor an infeed motion is produced by the spindle system.

The power transmission is conducted outwards by the hard-chrome plated slide rod (4).

The connecting rod is well sealed in its guidance by strippers and sealing rings. Therefore on the one hand the penetration of dirt, on the other hand escape of lubricant filled in by the producer is prevented as far as possible.

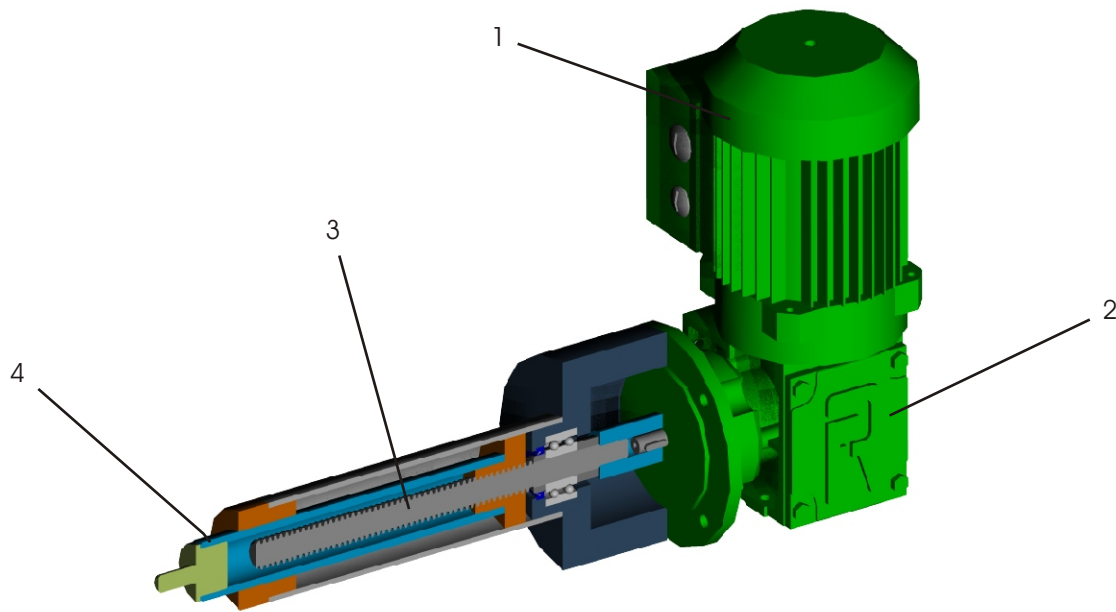

Pull/push-force:.

RAHMANN - electro linear cylinders are designed for the pull/push force specified in the catalogue.

In order to achieve a high operating safety and to guarantee high operating cycles, a power reserve is at drive's proposal.

The power reserve is realized by the drive unit and can range up to the twofold adjusting force.

For the prevention of damage at the system or machine, this force should be considered constructive.

For the containment of the power reserve, we offer as accessories a power control.

Adjustable stroke:

In the technical data the usable stroke is specified.

Because of the risk of sticking in the final positions, RAHMANN - electro linear cylinders must be switched off before reaching the final positions.

In order to guarantee the usable stroke, the RAHMANN - electro linear cylinders are equipped with safety zones, which enable a safe working in the stroke area.

Final position switch, position indication:

RAHMANN - electro linear cylinders can be equipped with reed switches or magnetic field sensors. The reed switches resp. magnetic field sensors are fastened on the guide cap tube and can be adjusted by shifting.

Upon request other switch- and position indications can be also mounted.

Reed switches:

The contacts of the reed switches are designed for voltages up to 250 VAC / 50W. They can be designed as break contact (NC) or as normally open contact (NO).

Magnetic field sensors:

The voltage of the magnetic field sensors is 5 - 50 VDC and is designed for a service voltage of max. 50W. Optionally sensors are used with NPN or PNP output.

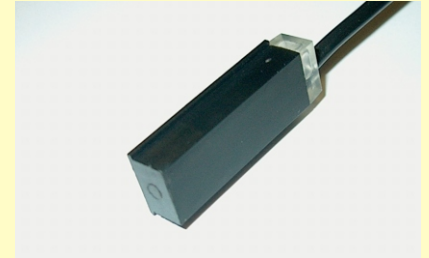

Self-locking, brake:

The used spindle systems are classified as self-locking.

Vibrations and crushes at RAHMANN - electro linear cylinders can affect the self-locking. Therefore a brake can be recommendable - depending upon location of installation.

Positioning motor, Profibus DP:

For the integration of RAHMANN - electro linear cylinders into a Profibus-DP-network, the type PLT is offered. The drive represents a locally element, which can be used for positioning and controlling. Additionally to the controlling functions the type PLT has three control inputs, one analog input and two control outputs. 8 positions can be deposited into the drive system, which will stored by Flash-ROM.

RAHMANN - electro linear cylinders of type PLT can be supplied also without Profibus-DP-connection.

This system represents a positioning unit, which can locally convert the tasks of controlling and positioning. Positioning tasks can be controlled by analog input (0-5V, 0-10V or 4-20mA) or 1-8 positions (initially- and/or time-dependently).

Special solutions:

RAHMANN - electro linear cylinders are manufactured customized up to a adjusting force of 500 KN.

As special solutions the electro linear cylinders can be offered with different drive variations (alternating current, threephase current-, direct current - motors) and customized fastenings.

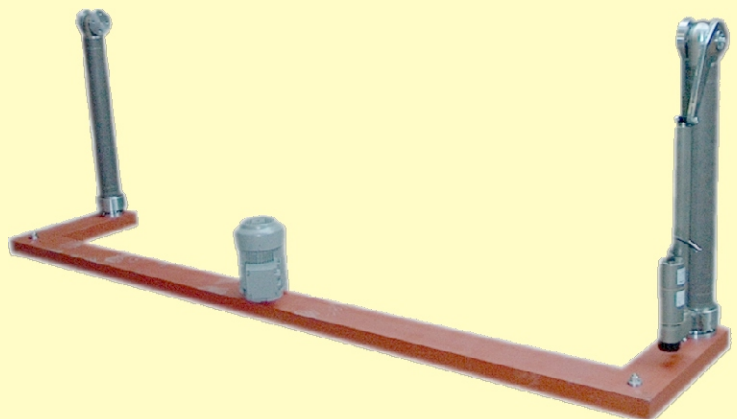

LT 4.. - LT 8..

1.000 N - 5.000 N

RAHMANN - electro linear cylinders with acme thread spindle and worm gear motor, installation size LT 4 .. - LT 8 ..

Technical data:

Installation size	Force (N)	Rated adjusting data			Starting Current (A)	Motor size
		Speed (mm/sec)	Rating (kW)	Current (A)		
LT 4	1.000	45	0,27	0,55	2,6	1
LT 5	2.000	45	0,37	0,78	3,8	2
		30	0,27	0,55	2,6	1
LT 6	3.000	45	0,55	0,94	4,3	3
		30	0,37	0,78	3,8	2
		20	0,27	0,55	2,6	1
LT 7	4.000	45	0,75	1,28	6,8	4
		30	0,55	0,94	4,3	3
		20	0,37	0,78	3,8	2
		15	0,27	0,55	2,6	1
LT 8	5.000	45	1,00	1,76	9,3	5
		30	0,75	1,28	6,8	4
		20	0,50	0,94	4,3	3
		15	0,37	0,78	3,8	2
		9	0,27	0,55	2,6	1

The mentioned values are standard values.
Variations and alterations are reserved.

Type code:

Installation size see table	LT 5	K	-	405	500	/	45	-	6	f	W	F	S..	Special edition S ...
Brake K = without B = with brake														Slide rod protection F = bellow T = telescope*
Voltage 405 = 3 X 400 V 50 Hz 505 = 3 X 500 V 50 Hz														Motor protection W = heat controller K = posistor
Stroke (mm) 250; 500; 750; 1000														Checkback signal e = without f = Reed switches (NO)** g = Reed switches (NC)** h = rotary pulse encoder k = 2 x g l = 2 x f m = f + h s = g + h
Adjusting speed (mm/sec) 45; 30; 20; 15; 9														
Fastening (motor side) 1 = central pivot 2 = central pivot and pedestal bearing 6 = knuckle joint														

*) Telescope slide rod protection only possible without acknowledge switch

***) Checkback signal for each running direction (e.g. 1 Reed switch retract, 1 Reed switch extract)

LT 4.. - LT 8..

Kind of fastening 1	
Stroke	X
250	501
500	751
750	1.001
1.000	1.251

Kind of fastening 2

Kind of fastening 2	
Stroke	X
250	501
500	751
750	1.001
1.000	1.251

Kind of fastening

Kind of fastening	
Stroke	X
250	712
500	962
750	1.212
1.000	1.462

Motor size 1 / 2

Motor size 3 / 4 / 5

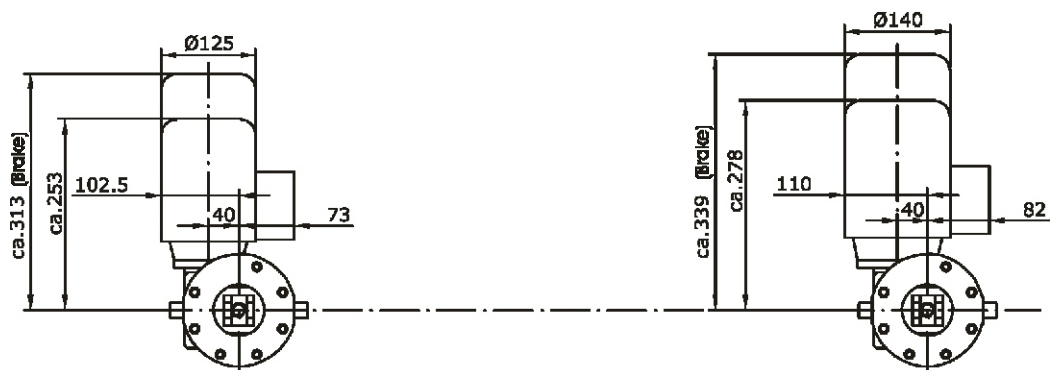

The mentioned values are standard values. Variations and alterations are reserved.
Motor dimensions can diversify !

LT 9..

7.500 N

RAHMANN - electro linear cylinders with acme thread spindle and worm gear motor, installation size LT 9 ..

Technical data:

Installation size	Force (N)	Rated adjusting data			Starting Current (A)	Motor size
		Speed (mm/sec)	Rating (kW)	Current (A)		
LT 9	7.500	45	1,40	2,45	15,0	6
		30	1,00	1,76	9,3	5
		20	0,75	1,28	6,8	4
		15	0,55	0,94	4,3	3
		9	0,37	0,78	3,8	2

The mentioned values are standard values.
Variations and alterations are reserved.

Type code:

Installation size	LT 9	Special edition	S ..
Brake K = without B = with brake	K	Slide rod protection F = bellow T = teleskope*	F
Voltage 405 = 3 X 400 V 50 Hz 505 = 3 X 500 V 50 Hz	405 / 500	Motor protection W = heat controller K = posistor	W
Stroke (mm) 250; 500; 750; 1000	45	Checkback signal e = without f = Reed switches (NO)** g = Reed switches (NC)** h = rotary pulse encoder k = 2 x g l = 2 x f m = f + h s = g + h	f
Adjusting speed (mm/sec) 45; 30; 20; 15; 9	6		6
Fastening (motor side) 1 = central pivot 2 = central pivot and pedestal bearing 6 = knuckle joint			

*) Telescope slide rod protection only possible without acknowledge switch

***) Checkback signal for each running direction (e.g. 1 Reed switch retract, 1 Reed switch extract)

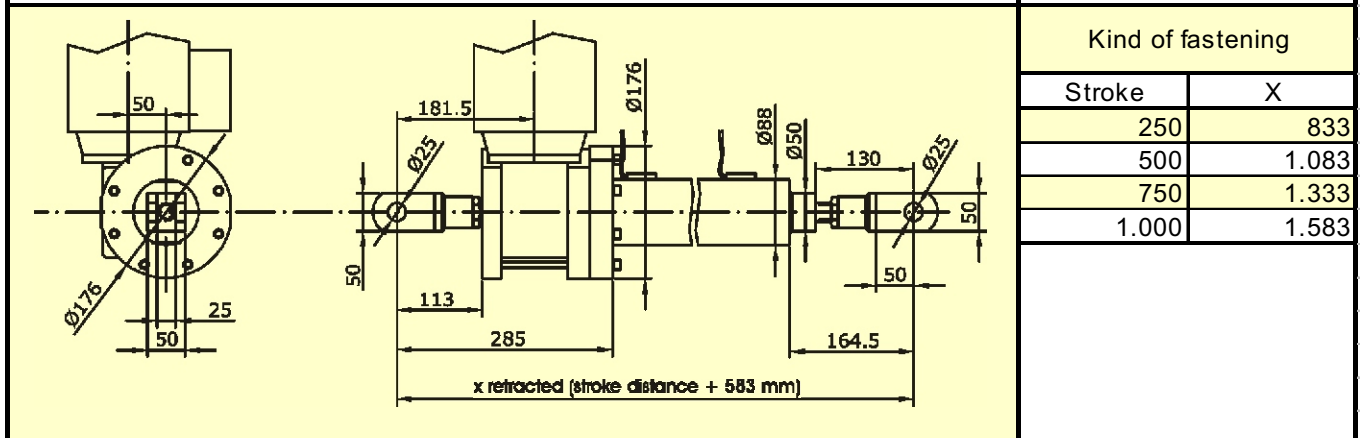
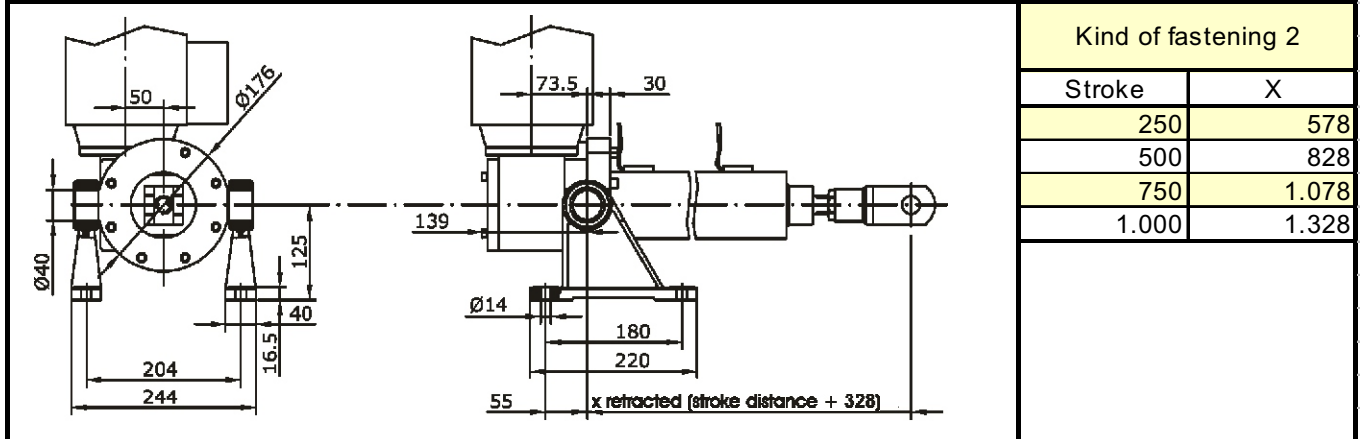
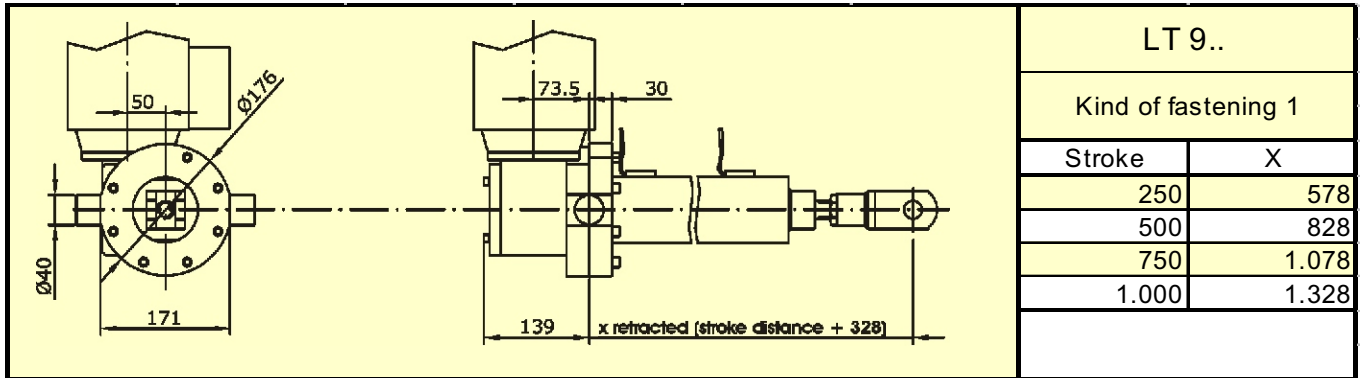

Motor size 2

Motor size 3 / 4

Motor size 5 / 6

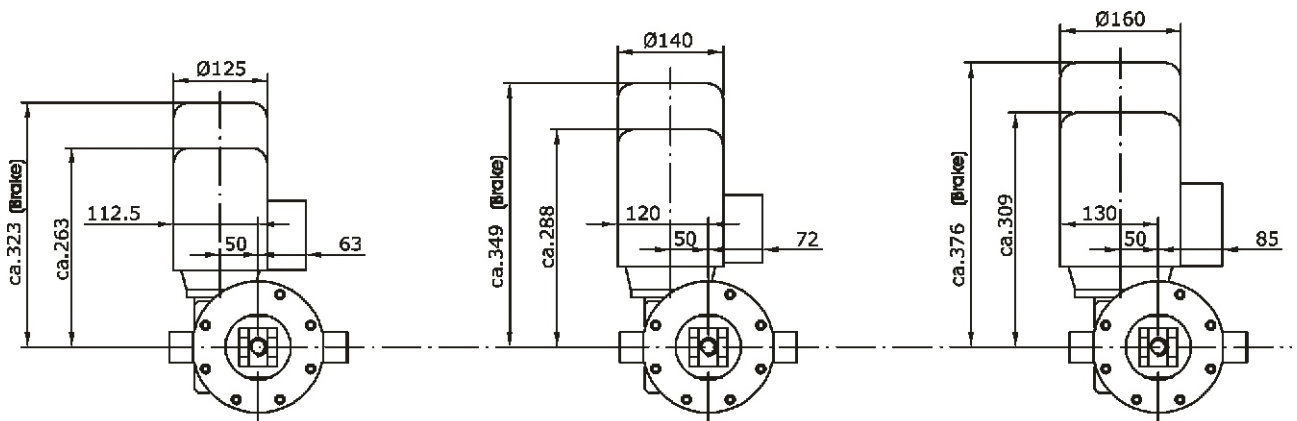

The mentioned values are standard values. Variations and alterations are reserved..
Motor dimensions can diversify !

LT 10..

10.000 N

RAHMANN - electro linear cylinders with acme thread spindle and worm gear motor, installation size LT 10 ..

Technical data:

Installation size	Force (N)	Rated adjusting data			Starting Current (A)	Motor size
		Speed (mm/sec)	Rating (kW)	Current (A)		
LT 10	10.000	45	2,70	4,5	28,0	8
		30	1,90	3,3	21,0	7
		20	1,40	2,45	15,0	6
		15	1,00	1,76	9,3	5
		9	0,55	0,94	4,3	3

The mentioned values are standard values.
Variations and alterations are reserved.

Type code:

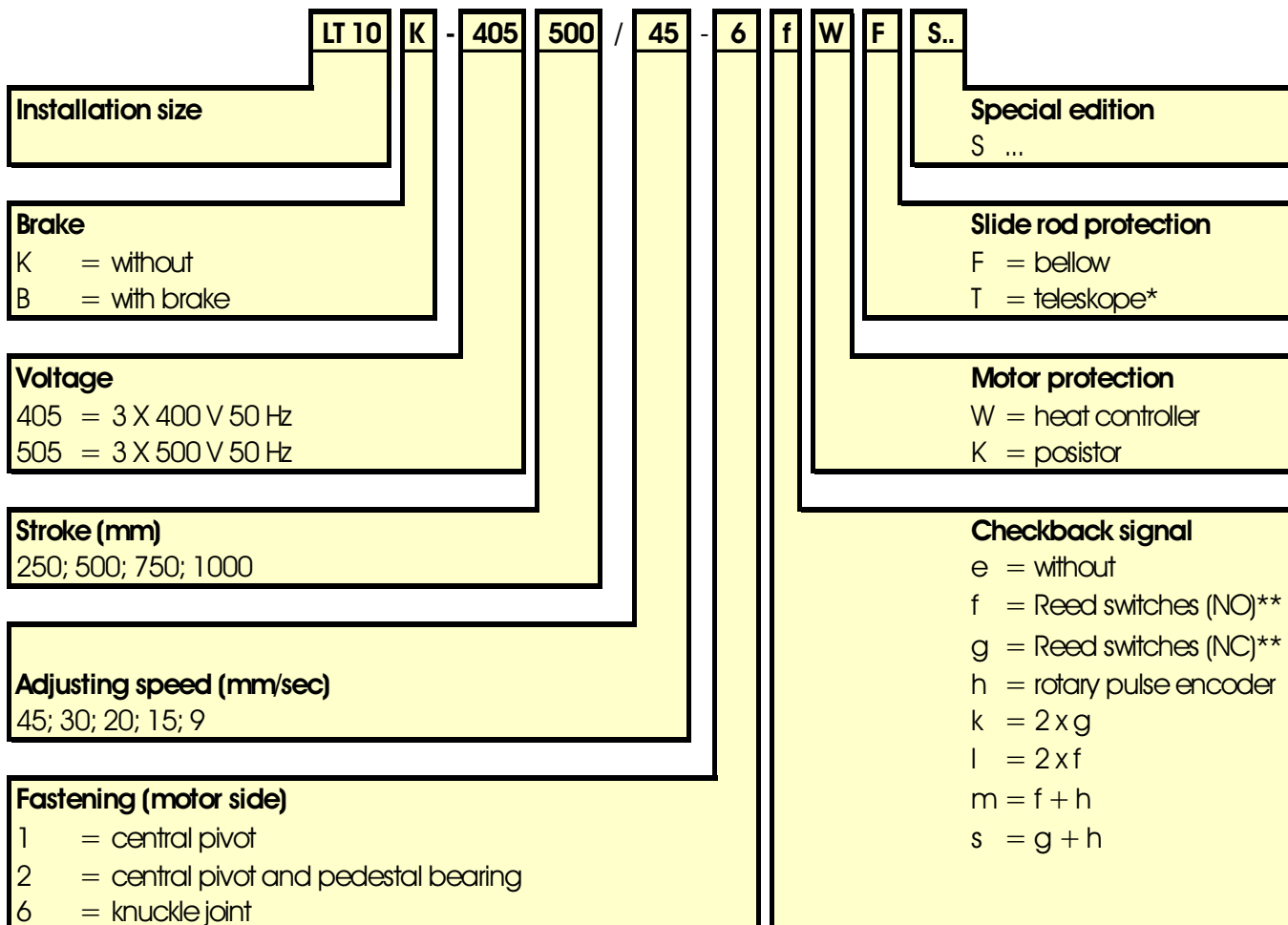

*) Telescope slide rod protection only possible without acknowledge switch

***) Checkback signal for each running direction (e.g. 1 Reed switch retract, 1 Reed switch extract)

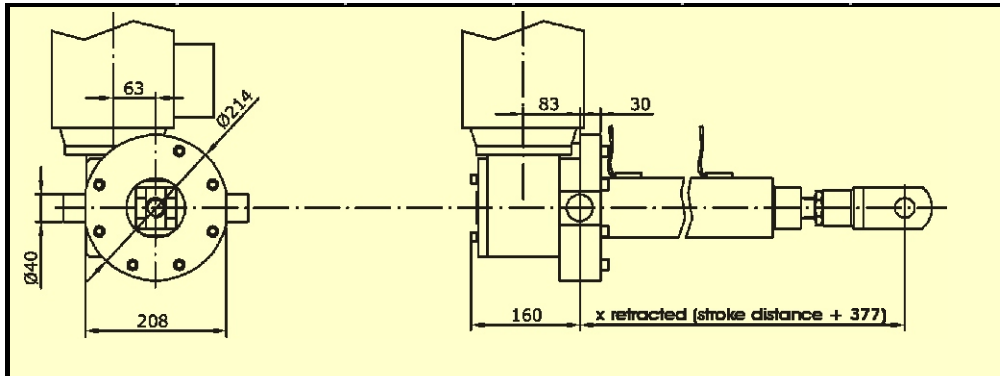

LT 10..	
Kind of fastening 1	
Stroke	X
250	627
500	877
750	1.127
1.000	1.377

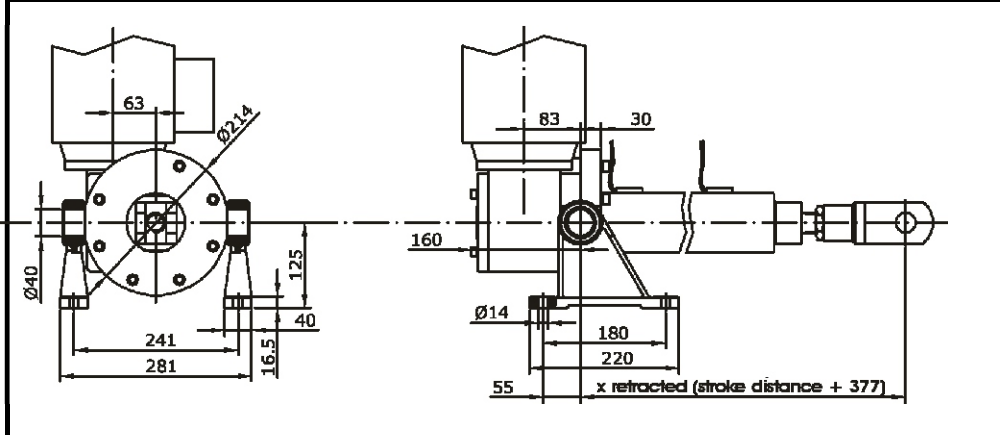

Kind of fastening 2	
Stroke	X
250	627
500	877
750	1.127
1.000	1.377

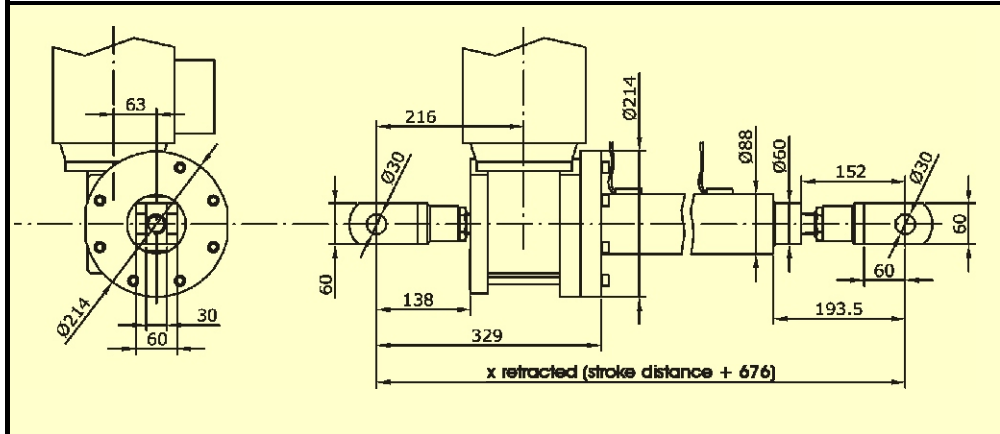

Kind of fastening 6	
Stroke	X
250	926
500	1.176
750	1.426
1.000	1.676

Motor size 3 / 4

Motor size 5 / 6

Motor size 7

Motor size 8

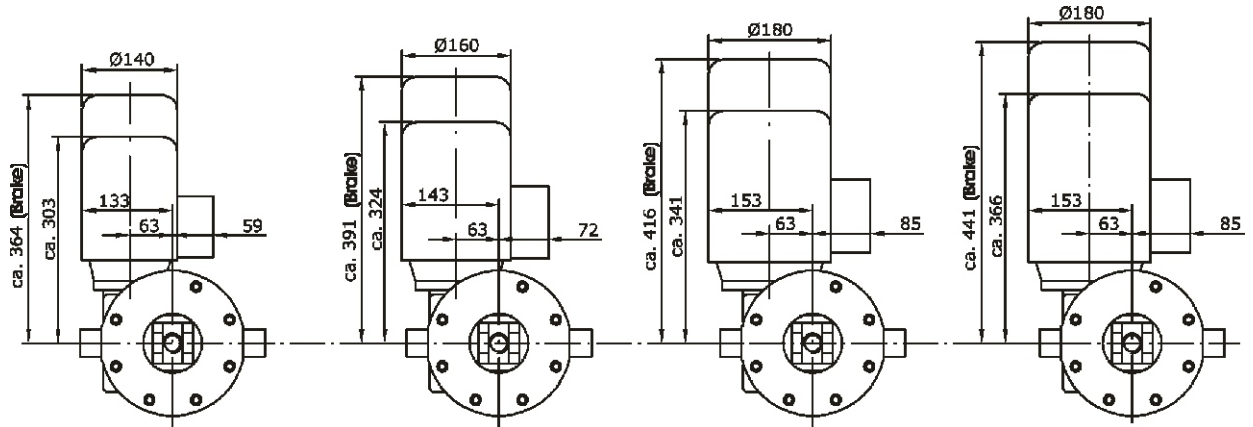

The mentioned values are standard values. Variations and alterations are reserved.
Motor dimensions can diversify !

LT 11.. - LT 12..

17.500 N - 23.000 N

RAHMANN - electro linear cylinders with acme thread spindle and worm gear motor, installation size LT 11 .. - LT 12 ..

Technical data:

Installation size	Force (N)	Rated adjusting speed			Starting Current (A)	Motor size
		Speed (mm/sec)	Rating (kW)	Current (A)		
LT 11	17.500	45	2,70	4,5	28,0	8
		30	2,70	4,5	28,0	8
		20	1,90	3,3	21,0	7
		15	1,40	2,45	15,0	6
		9	1,00	1,76	9,3	5
LT 12	23.000	45	3,70	6,4	42,0	9
		30	3,70	6,4	42,0	9
		20	2,70	4,5	28,0	8
		15	1,90	3,3	21,0	7
		9	1,00	1,76	9,3	5

The mentioned values are standard values.
Variations and alterations are reserved.

Type code:

Installation size see table	LT 11	K	-	405	500	/	45	-	6	f	W	F	S..	Special edition S ...
Brake K = without B = with brake														Slide rod protection F = bellow T = teleskope*
Voltage 405 = 3 X 400 V 50 Hz 505 = 3 X 500 V 50 Hz														Motor protection W = heat controller K = posistor
Stroke (mm) 250; 500; 750; 1000														Checkback signal e = without f = Reed switches (NO)** g = Reed switches (NC)** h = rotary pulse encoder k = 2 x g l = 2 x f m = f + h s = g + h
Adjusting speed (mm/sec) 45; 30; 20; 15; 9														
Fastening (motor side) 1 = central pivot 2 = central pivot and pedestal bearing 6 = knuckle joint														

*) Telescope slide rod protection only possible without acknowledge switch

***) Checkback signal for each running direction (e.g. 1 Reed switch retract, 1 Reed switch extract)

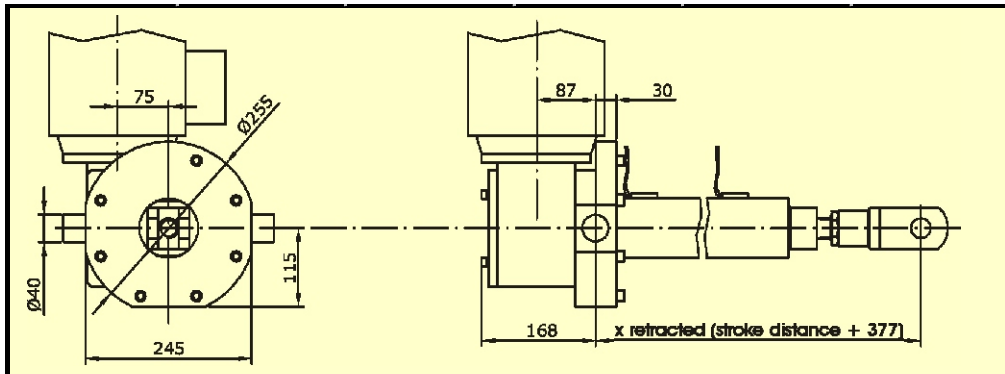

LT 11.. / LT 12..

Kind of fastening 1

Stroke	X
250	627
500	877
750	1.127
1.000	1.377

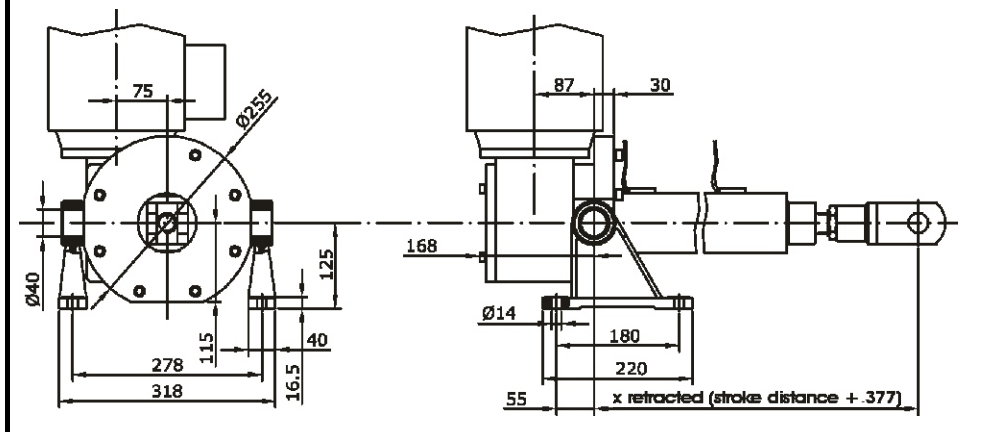

Kind of fastening 2

Stroke	X
250	627
500	877
750	1.127
1.000	1.377

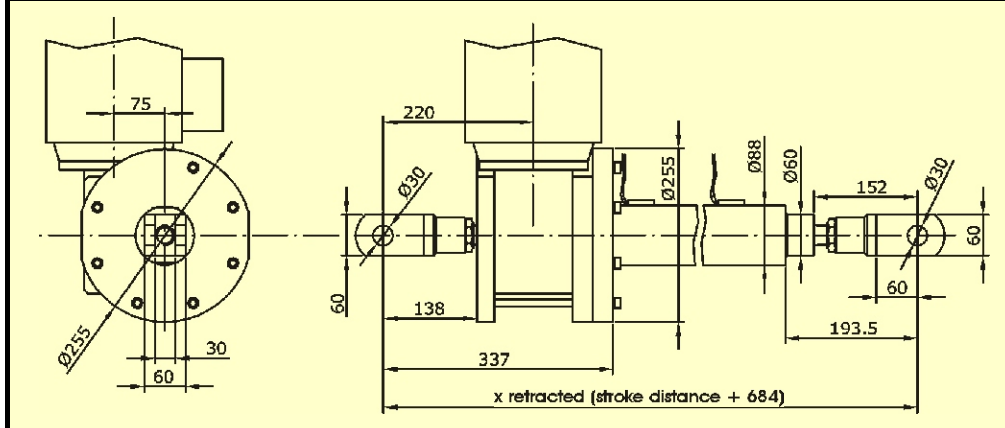

Kind of fastening 6

Stroke	X
250	934
500	1.184
750	1.434
1.000	1.684

Motor size 5/6

Motor size 7

Motor size 8

Motor size 9

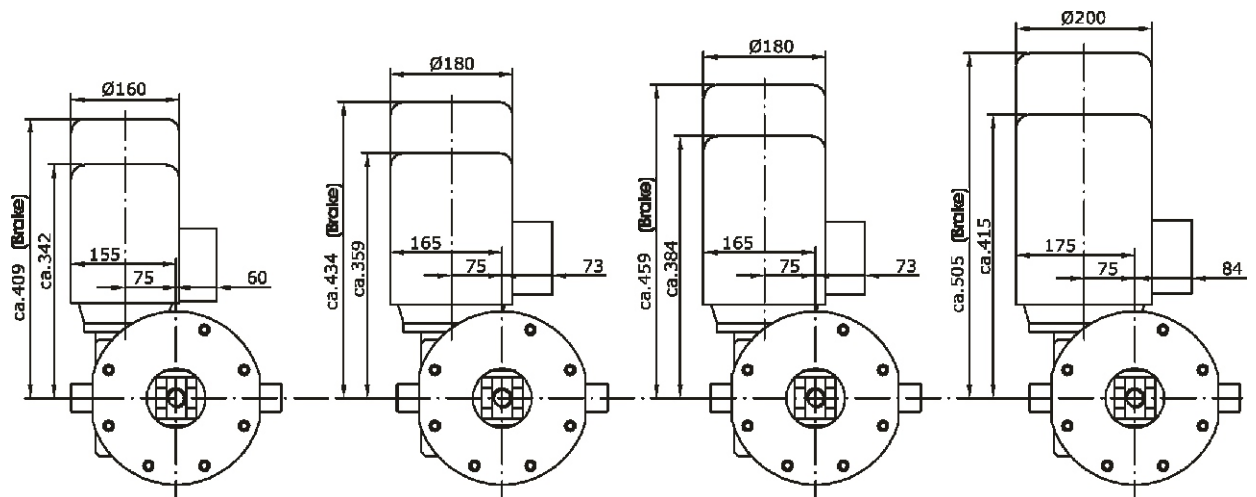

The mentioned values are standard values. Variations and alterations are reserved.
Motor dimensions can diversify !

ACCESSORIES

LT 4.. - LT 8..		Telescope slide rod protection*	Bellow
Stroke	X		
250	125		
500	200		
750	280		
1.000	360		
LT 9..			
Stroke	X		
250	125		
500	200		
750	280		
1.000	360		
LT 10..			
Stroke	X		
250	125		
500	200		
750	280		
1.000	360		
LT 11.. - LT 12..			
Stroke	X		
250	125		
500	200		
750	280		
1.000	360		

*) Slide rod protection only possible without acknowledge switch.

<p style="text-align: center;">Frequency converter</p> <p>RAHMANN - electro linear cylinders are designed for frequency converter type serie SC... In association with a rotary encoder additionally tasks can be realized, such as</p> <ul style="list-style-type: none"> ● Positioning control ● Torque limitation ● Digitally ganging control 	
<p style="text-align: center;">Encoder</p> <p>RAHMANN - electro linear cylinders can be equipped with rotary pulse encoder. The rotary encoder has a resolution up to 1024 pulses/rotation. As output signal it offers two HTL or TTL signals, which are staggered against each other at 90°. Optionally the signals can be inverted over again and a zero track can be integrated.</p>	
<p style="text-align: center;">Acknowledge switch</p> <p>The acknowledge unit can be offered optional for the Reed switch. As far as 4 acknowledge switches or two acknowledge switches and a potentiometer can be mounted there. The potentiometric signal can be executed additionally as 4-20mA signal.</p>	
<p style="text-align: center;">Motor-torque control</p> <p>The torque control unit TCU 100 is an electronic load measurer. It supplies a signal of 0-10V, also with cylinders with variable adjustment speeds, operated by frequency converter. The integrated limit relay (0-100%), adjustable start- and limit time, the unit is a universal limit reporter.</p>	



RAHMANN GmbH

Clausewitzstraße 36
D-42389 Wuppertal

Internet: www.rahmann-gmbh.com

@Mail: info@rahmann-gmbh.com

Tel.: +49 (202) 2 60 71 -0

Fax.: +49 (202) 2 60 71 -50