

SERIES

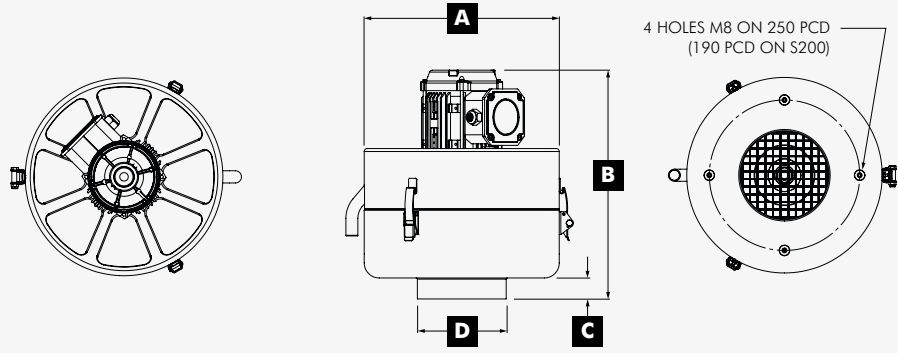

The compact S series with airflows from 180m³/hr to 950m³/hr



Model	Airflow m ³ /hr	Motor 1	A mm	B mm	C mm	D mm	Weight kg	Noise 2 dBA
S200	180 @ 50Hz	0.18kW 50Hz 200v, 220v, 380v, 400v, 415v	260	302	30	73	9	62
	215 @ 60Hz	0.18kW 60Hz 220v, 230v, 240v, 440v, 460v, 480v						
S400	425 @ 50Hz	0.55kW 50Hz 200v, 220v, 380v, 400v, 415v	325	381	35	148	14	65
	500 @ 60Hz	0.55kW 60Hz 220v, 230v, 240v, 440v, 460v, 480v						
S800	800 @ 50Hz	0.55kW 50Hz 200v, 220v, 380v, 400v, 415v	325	435	35	148	15	67
	950 @ 60Hz	0.55kW 60Hz 220v, 230v, 240v, 440v, 460v, 480v						

FX SERIES

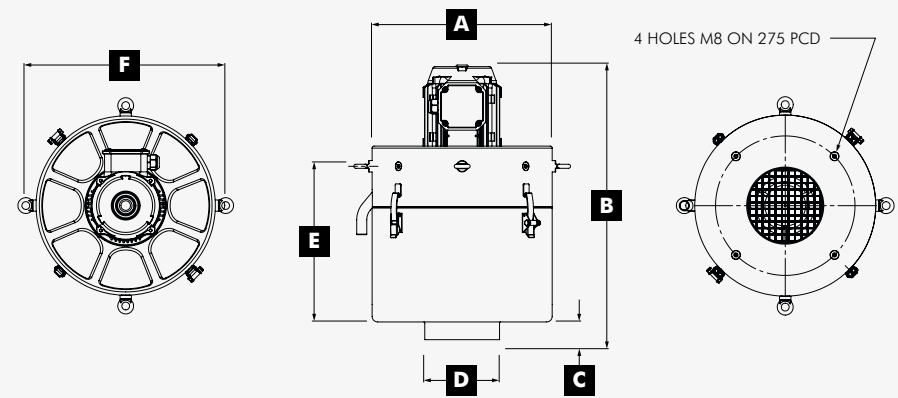

The Filtermist FX series has four models with airflows from 1250m³/hr to 2750m³/hr



Model	Airflow m ³ /hr	Motor 1	A mm	B mm	C mm	D mm	E mm	F mm	Weight kg	Noise 2 dBA
FX4002	1250 @ 50Hz	1.1kW 50Hz 200v, 220v, 380v, 400v, 415v	357	544	35	148	309	398	25.8	70
	1500 @ 60Hz	1.5kW 60Hz 200v, 220v, 230v, 440v, 460v, 480v								
FX5002	1675 @ 50Hz	1.5kW 50Hz 200v, 220v, 380v, 400v, 415v	357	634.5	35	198	378	398	31.8	71
	2000 @ 60Hz	2.2kW 60Hz 200v, 220v, 230v, 440v, 460v, 480v								
FX6002	2000 @ 50Hz	2.2kW 50Hz 200v, 220v, 380v, 400v, 415v	438	638.5	35	198	432	485	36.8	73
	2400 @ 60Hz	2.2kW 60Hz 200v, 220v, 230v, 440v, 460v, 480v								
FX7002	2750 @ 50Hz	2.2kW 50Hz 200v, 220v, 380v, 400v, 415v	438	638.5	35	198	432	485	36.8	73



Efficient oil mist removal
Proven reliability since 1969



Filtermist Customers Include

- ABB
- AEG
- Airbus Industrie
- BAE Systems
- Black & Decker
- BMW
- Borg Warner
- Bosch
- Caterpillar
- Cincinnati Milacron
- Daewoo
- Dana Corporation
- Doosan
- Eaton Corporation
- Fiat
- Ford
- GE
- General Motors
- Hardinge
- Honda
- Hyundai
- Ingersoll Rand
- John Deere
- Kawasaki
- Koyo
- Lufthansa
- Makino
- Mercedes Benz
- Mitsubishi
- Nissan
- NSK
- Okuma
- Panasonic
- Philips
- Peugeot
- Renault
- Rolls Royce
- Samsung
- Siemens
- Timken
- Toyota
- TRW
- Volkswagen
- Yamazaki Mazak
- Zanussi
- Zeiss

Sales Enquiries

E: sales@filtermist.com
T: +44 (0)1952 290500



Oil Mist Collectors



Trusted by world leading manufacturers since 1969

Filtermist units efficiently remove oil & coolant mist, fume and steam in thousands of manufacturing operations around the world

Compact | Quiet | Efficient

Why Use Filtermist Units



- Oil mist is hazardous to health
- Oil mist causes slippery floors and can cause damage to electrical switchgear and circuitry
- Oil mist can lead to coating of ventilation pipes - a potential fire risk
- Official regulations are becoming increasingly stringent around the world
- Filtermist units help to reduce energy and heating costs by recycling clean air back into the factory
- No expensive media filters to replace meaning low maintenance costs

How Filtermist Units Work ►

- 1 Oil mist is removed at source
- 2 Oil mist is removed from the air by centrifugal impaction
- 3 Clean oil is returned to machine
- 4 Clean air is returned to workplace
- 5 Smoke and fume can be removed and efficiency increased with the addition of a clip-on afterfilter



A perforated drum containing four specially designed vanes rotates at high speed.

Oil mist is drawn into the drum where it impacts on the vanes at high velocity, causing the mist to coalesce. Special drum pads assist the coalescing process, filter out stray solid particles and reduce noise.

Centrifugal force pushes oil to the unit's outer case where it drains back to the machine for re-use or collection. Clean air is returned to the workshop through the top of the unit.

Proven Experience ►

UK manufacturer, Filtermist International Ltd, has almost 50 years' experience in providing effective oil mist extraction systems.

Filtermist has worked alongside government research institutes and global machine manufacturers to develop the most well-known and well-used oil mist extraction system in the world.

Filtermist units are in operation on tens of thousands of applications - from high precision CNC machining centres, to traditional open grinders.

Filtermist is an industry standard from aerospace and automotive, to food processing and medical device manufacture.

Units are available in mild steel and stainless steel with dozens of installation accessories to create bespoke solutions for almost any type of oil mist problem.

Filtermist units are trusted by world leading manufacturers to protect people from harmful airborne oil mist particles.

Local support in more than 60 countries worldwide

Mounting Options

Direct Mounting

The compact and lightweight design of Filtermist units means they can also be directly mounted on enclosed machine tools - saving valuable floor space and removing the need for additional brackets.



Floor Stands

The Filtermist extendable floor stand comes in sections for easy transportation. The stand height is fully adjustable with the base plate pre-drilled for bolting to the workshop floor. The stands are made for the S Series and FX Series with customised fixings to ensure the units are securely mounted.

Filtermist also offers a robust low level stand designed to make servicing simple.

Machine Tool Stands

These versatile stands are designed to fit directly onto the machine tool where floor space is at a premium. Each installation takes the location, application, access for ongoing maintenance and size of unit into account. Machine tool stands are available for S Series and FX Series units.

CSX Mobile Stand With Pre-Separator

A combined stand that includes an inbuilt pre-separator - ideal for heavy duty applications such as grinding machines. The stand benefits from large doors to allow easy access for servicing and maintenance. The CSX stand comes complete with 4 locking castors, 90-degree inlet bend, pre-separator and 50mm diameter drain with tap.

CSX is only compatible with FX5002, FX6002 & FX7002 units. Please contact Filtermist for more details.

S FUSION Neat Oil Mist Collector

The compact, cost effective way to remove submicron neat oil mist particles from workshop air.

S Fusion successfully removes submicron particles generated in neat oil applications by combining a hi-tech synthetic self-draining media filter with Filtermist's proven centrifugal technology - offering an effective alternative to other products in the high-pressure coolant market.

- Compact
- Cost effective
- Long-life
- Efficient
- Self-draining
- Patented suction system



• Dedicated high-pressure neat oil solution

Accessories

The Filtermist system is complemented by numerous accessories to suit your installation



Compact Cyclone

Filtermist cyclones are designed to collect dust and swarf before it enters the Filtermist unit.

The system is attached to the inlet of the Filtermist unit and the contaminated air passes through it. The low-pressure area within the separator encourages the heavier particles to fall to its base where they can be easily removed.

Filtermist has re-designed the cyclone, without impacting on the efficiency of the unit, into a shorter system to complement its compact extraction units.



Afterfilters

Afterfilters are designed for the removal of oil smoke and any residual fine mist particles. Afterfilters are used in addition to the Filtermist unit on applications where the exhaust air needs final cleaning before being returned to the workshop.

Two types of High Efficiency afterfilter are available - F8 and H13. The highest grade offers up to 99.95% filtration efficiency.

Fusion Filter

The Fusion Filter successfully removes submicron particles generated in high-pressure neat oil applications when combined with Filtermist's proven centrifugal technology. Compatible with S400 and S800 Filtermist units.



Maintenance Kits

Filtermist provides a range of easy to fit, low cost service and maintenance kits. Filtermist spares, including its exclusive fibre technology drum pads, are specially designed to ensure that the unit constantly extracts efficiently and safely.

Genuine Filtermist pads use the latest filter technology to provide greater surface area - enabling increased volumes of oil mist to be collected.

Always use official Filtermist spares to guarantee that your oil mist extraction unit maintains its optimum performance.



F MONITOR

Filtermist's monitoring system uses coloured warning lights to advise machine operators when an oil mist collector needs servicing, or if any of the filters are blocked. Filtermist advises that its units should be serviced every 2000 hours they are in use.

F Monitor can be retro-fitted to the complete Filtermist range and is sold as an optional accessory on all Filtermist units.

As well as being compatible with all Filtermist oil mist collectors, F Monitor can also be used to monitor airflow in other types of air extraction and filtration systems.